

Lorem ipsum



...for a more sustainable world

**POLYPROPYLENE CUPS
REUSABLE AND CUSTOMIZABLE**

GENERAL CATALOG





...for a more sustainable world

GENERAL CHARACTERISTICS

Homo Polypropylene is a durable, resistant and functional plastic material, ideal to be reused countless times, finally being 100% recyclable.

The cups are light, stackable and with a surface finish adapted for a good hold.

They can be washed in the dishwasher, easily resisting the washing temperatures necessary for cleaning and disinfection.

The regulations for food use within the EC regulation 1935/2004 of 2004 are complied with.

Bisphenol A free

Ideal cups for any sustainable and environmentally friendly event.



Homopolymer
homopolypropylene



Microwave safe



Food Use Product

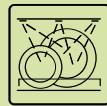

Dishwasher safe

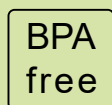

Bisphenol A Free



Recyclable material



...for a more sustainable world

PRINTING TECHNIQUES:

The printing or personalization techniques of the cups and other products are carried out using screen printing techniques and in full color with the In Mold Labeling "IML" system. These printing techniques are of high quality and guarantee its durability and permanence.

SERIGRAPHY

Screen printing is an ancient technique. The design is applied to the cups through a polyester cloth adhered to a rigid frame where the image to be printed has previously been prepared.

The decoration is of the highest quality, resistant and durable. Optimal technique for the reuse of the product.

Once the product is decorated, it complies with Food Safety Regulations.

IN MOULD LABELING (IML)

The In Mold Labeling printing technique is based on the application of a Homo Polypropylene label, previously decorated in full colour, inside the injection mold in such a way that the product comes out completely finished and decorated.

The process and decoration is of the highest quality, resistant and durable. Optimal for its reuse.

Once the product is decorated, it complies with Food Safety Regulations.

Ideal cups for coffee and shots

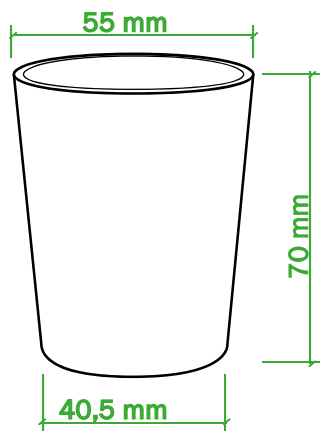

Material: Homo polypropylene

Capacity: 11cl

Weight: 11 grams

Surface finish: Translucent

Cup colour:



Printing techniques: Screen printing or IML

Shipping with box

Box units: 300 u.

Box measures: 29x23x23 cm

Box weight: 4.3 Kg

Shipping with pallet

Pallet units: 25.200 u.

Boxes per pallet: 84 u

Pallet measurements: 120x80x1600 cm

Pallet weight: 376 Kg



...for a more sustainable world

GOT20

(CUP CL 20)

Ideal glass for vending, coffee and cut

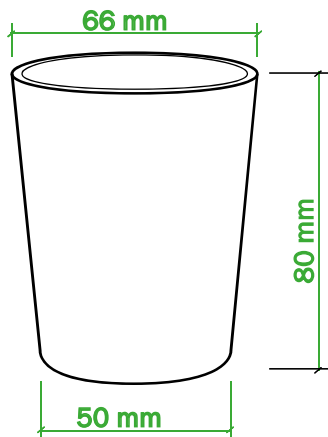

Material: Homo polypropylene

Capacity: 19 cl

Weight: 18 gr

Surface finish: Translucent

Cup colour:



Printing techniques: Screen printing or IML

Shipping with box

Box units: 300 u.

Box measures: 34x27x29 cm

Box weight: 6,4 Kg

Shipping with pallet

Pallet units: 14.400 u.

Boxes per pallet: 48 u.

Pallet measurements: 120x80x1900 cm

Pallet weight: 322 Kg



Polypropylene



suitable for food use



Bisphenol A Free



Microwave safe



Dishwasher safe



Recyclable

Ideal glass for soft drinks, beer, tastings,
mulled wine, broths and chocolate

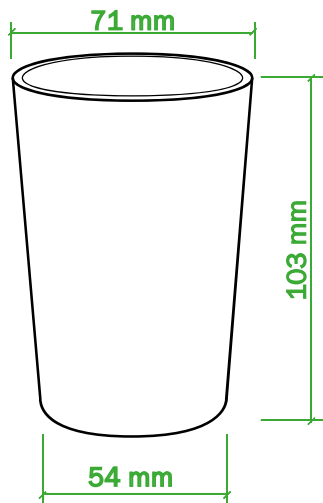

Material: Homo polypropylene

Capacity: 28 cl

Weight: 27 gr

Surface finish: Translucent

Cup colour:



Printing techniques: Screen printing or IML

Shipping with box

Box units: 100 / 500 (u.)

Box measures: 34x27x29 / 49x37x8,5 (cm)

Box weight: 2,7 / 13,5 (kg)

Shipping with pallet

Pallet units: 12.000 u.

Boxes per pallet: 24 u.

Pallet measurements: 120x80x1950 cm

Pallet weight: 363 Kg





...for a more sustainable world

GOT33 (CUP CL 33)

It is the cup most used in private, collective, popular parties, concerts, festivals and all kinds of events. Ideal for beer rods

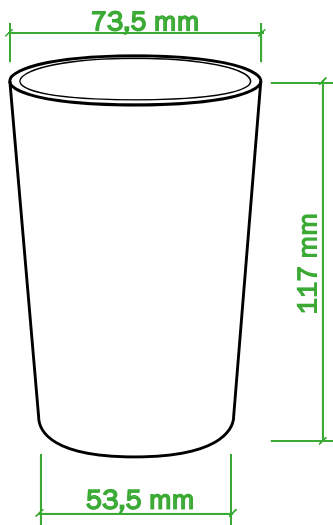

Material: Homo polypropylene

Capacity: 33 cl

Weight: 29 gr

Surface finish: Translucent

Cup colour:

Opaque



Translucent



Printing techniques: Screen printing or IML

Shipping with box

Box units: 25 / 250 / 500 (u.)

Box measures: 60x40x10/60x40x15/60x40x32 (cm)

Box weight: 5 / 7,5 / 15 (kg)

Shipping with pallet

Pallet units: 12.000 u.

Boxes per pallet: 24 u.

Pallet measurements: 120x80x1950 cm

Pallet weight: 375 Kg





...for a more sustainable world

GOT40 (CUP CL 40)

Cups for all types of parties, concerts, festivals and any type of event.
Ideal for soft drinks with ice, mixed drinks, and long drinks. Perfect for 33cl cans.

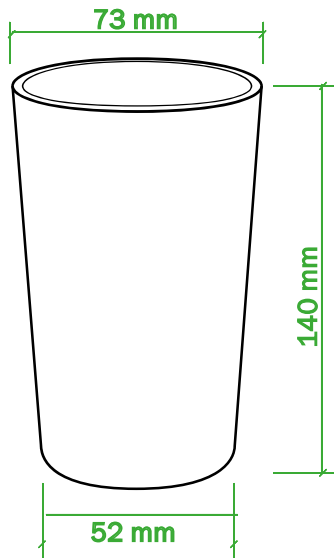

Material: Homo polypropylene

Capacity: 40 cl

Weight: 38 gr

Surface finish: Translucent

Cup colour:



Printing techniques: Screen printing or IML

Shipping with box

Box units: 100 / 200 / 400 (u.)

Box measures: 60x40x10/60x40x15/60x40x32 (cm)

Peso caja: 4 / 8 / 16 (kg)

Shipping with pallet

Pallet units: 8.000 u.

Boxes per pallet: 24 u.

Pallet measurements: 120x80x1950 cm

Pallet weight: 335 Kg



GOT50 (CUP CL 50)

Ideal glass for combined with ice

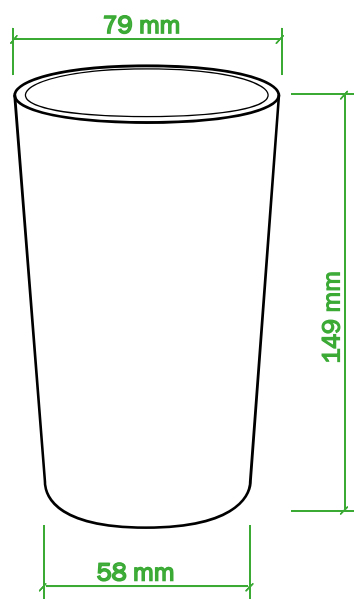

Material: Homo polypropylene

Capacity: 50 cl

Weight: 42 gr

Surface finish: Translucent

Cup colour:



Printing techniques: Screen printing or IML

Shipping with box

Box units: 80 / 400 (u.)

Box measures: 60x40x10 / 72X42,5X25 (cm)

Box weight: 4 / 18 (kg)

Shipping with pallet

Pallet units: 6.000 u.

Boxes per pallet: 16 u.

Pallet measurements: 120x80x1850 cm

Pallet weight: 283 Kg

 Polypropylene	 suitable for food use	 Bisphenol A Free
 Microwave safe	 Dishwasher safe	 Recyclable



...for a more sustainable world

GOT50S (Type cider) (CUP CL 50)

Cups for all types of parties, concerts, festivals and any type of event.
Ideal for soft drinks with ice, mojitos, mixed drinks, long drinks.

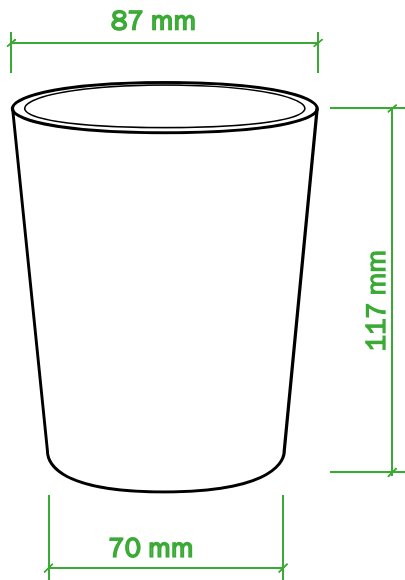

Material: Homo polypropylene

Capacity: 50 cl

Weight: 48 gr

Surface finish: Translucent

Cup colour:



Printing techniques: Screen printing or IML

Shipping with box

Box units: 80 / 300 u

Box measures: 60x40x10/60x40x32 (cm)

Box weight: 5 / 15,5 (kg)

Shipping with pallet

Pallet units: 6.000 u.

Boxes per pallet: 24 u

Pallet measurements: 120x80x1950 cm

Pallet weight: 305 Kg

Ideal glass for pints of beer and mixed with ice

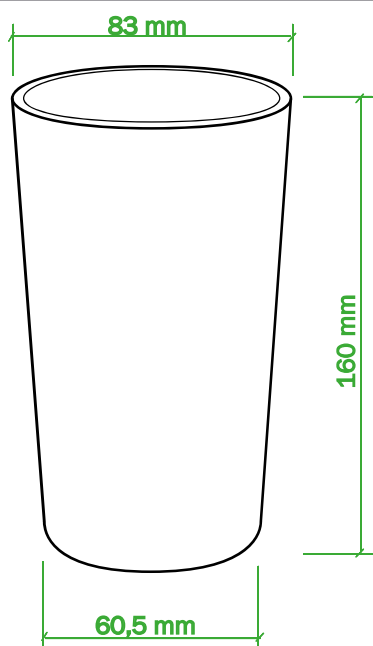

impresión en IML-DG



Material: Homo polypropylene

Capacity: 58.5 cl

Weight: 54 grams

Surface finish: Translucent

cup colour:



Printing techniques: Screen printing or IML-DG

Shipping with box

Box units: 60 / 300 (u.)

Box measures: 60x40x10 / 72X42,5X25 (cm)

Box weight: 4 / 17 (kg)

Shipping with pallet

Pallet units: 4.800 u.

Boxes per pallet: 16 u.

Pallet measurements: 120x80x1850 cm

Pallet weight: 290 Kg



...for a more sustainable world

GOT90 (katxi)

(CUP CL 90)

Ideal glass for pints of beer and mixed with ice

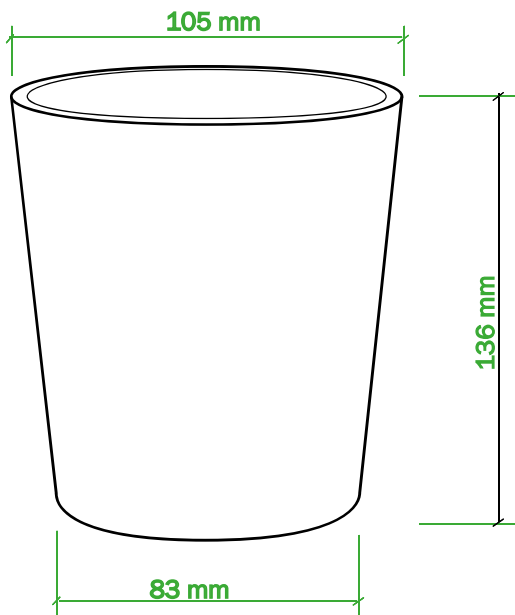

Material: Homo polypropylene

Capacity: 90 cl

Weight: 51 gr

Surface finish: Translucent

Cup colour:



Printing techniques: Screen printing or IML-DG

Shipping with box

Box units: 200 u.

Box measures: 60x40x32 cm

Box weight: 11,2 kg

Shipping with pallet

Pallet units: 4.800 u.

Boxes per pallet: 24 u

Pallet measurements: 120x80x1950 cm

Pallet weight: 255 Kg





...for a more sostenible world

Riu Glorieta, 16-3-3-A
43850 CAMBRILS (Tarragona)
www.monigots.com
info@monigots.com
Telf. oficina 977 622 146